

|      |         |               |          |
|------|---------|---------------|----------|
| REV. | ECN NO. | MODIFIED MARK | APPROVED |
| A    | —       | FIRST RELEASE |          |

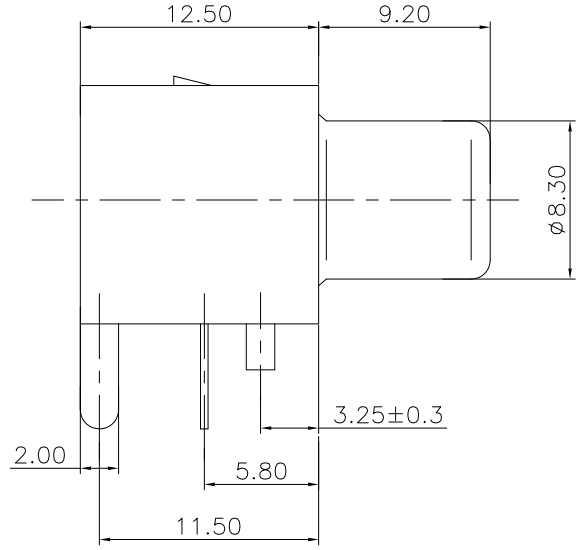

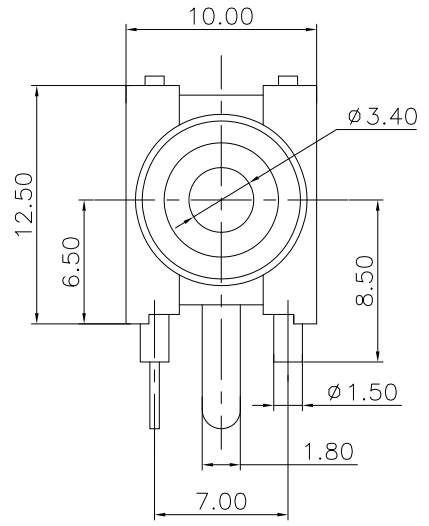

NOTES:  
 ELECTRICAL:  
 1:RATED CURRENT: 0.2A Max.  
 2:RATED VOLTAGE: 50V AC.  
 3:CONTACT RESISTANCE: 30 MILLIOHMS Max.  
 AFTER TESTING:100 MILLIOHMS Max.  
 4:INSULATION RESISTANCE: 100 MEGAOHMS Min.  
 5:DIELECTRIC WITHSTANDING VOLTAGE: 500 VAC Min.  
 MECHANICAL:  
 1:INSERTION FORCE: 3N-30N.  
 2:WITHDRAWAL FORCE: 3N-30N.  
 3:DURRABILITY: 100 CYCLES.  
 ENVIRONMENTAL:  
 TEMPERATURE RANGE: -20°C TO 60°C.

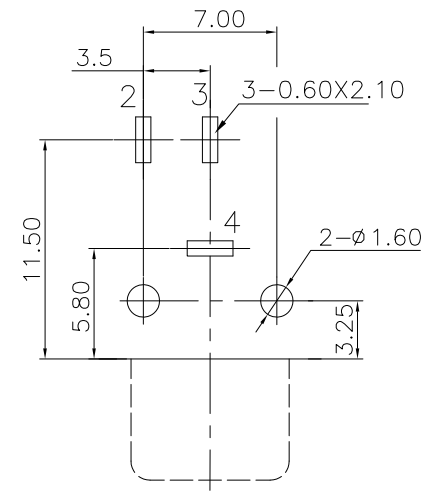

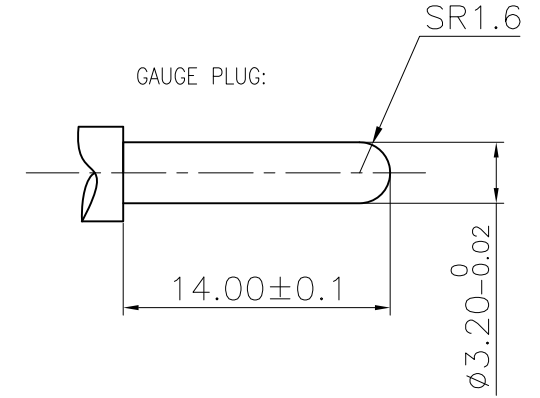
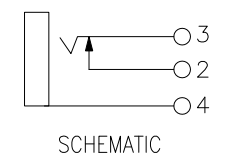
PCB LAYOUT  
TOP VIEW



|  |      |                                    |   |                     |   |
|--|------|------------------------------------|---|---------------------|---|
| ANGLE  | ±5°  | MODEL NAME: RCA-101B<br>(PART NO.) |  广东正宝科技有限公司<br>GUANGDONG TRENPRO TECHNOLOGY CO. LTD. |                     |   |
| 63 < L   | ±0.5 |                                    |   |                     |   |
| 16 < L ≤ 63  | ±0.4 |                                    |   |                     |   |
| 4 < L ≤ 16   | ±0.3 |                                    |   |                     |   |
| L ≤ 4  | ±0.2 | MAT'L:<br>See table                | DESIGN:X.H.Wang 11/01'18  | TITLE: RCA PIN JACK |   |
| TOL TABLE:   |      | FINISH:<br>See table               | CHECKED:L.W.Wu 11/01'18   | DWG NO.:            |   |
| THIS DOCUMENT IS THE PROPERTY OF TRENPRO TECHNOLOGY CO. LTD.,NO PART THEREOF MAY BE REPRODUCED AND USED WITHOUT THE PRIOR WRITTEN CONSENT OF THE OWNER |      | Q'TY:/                             | APPROVED:X.Q.Hu 11/01'18  | UNIT: mm            | VIEW:  |
|  |      |                                    |   | SCALE: 5:1          | SHEET: 1/1  |
|  |      |                                    |   |                     | SIZE: A3  |