

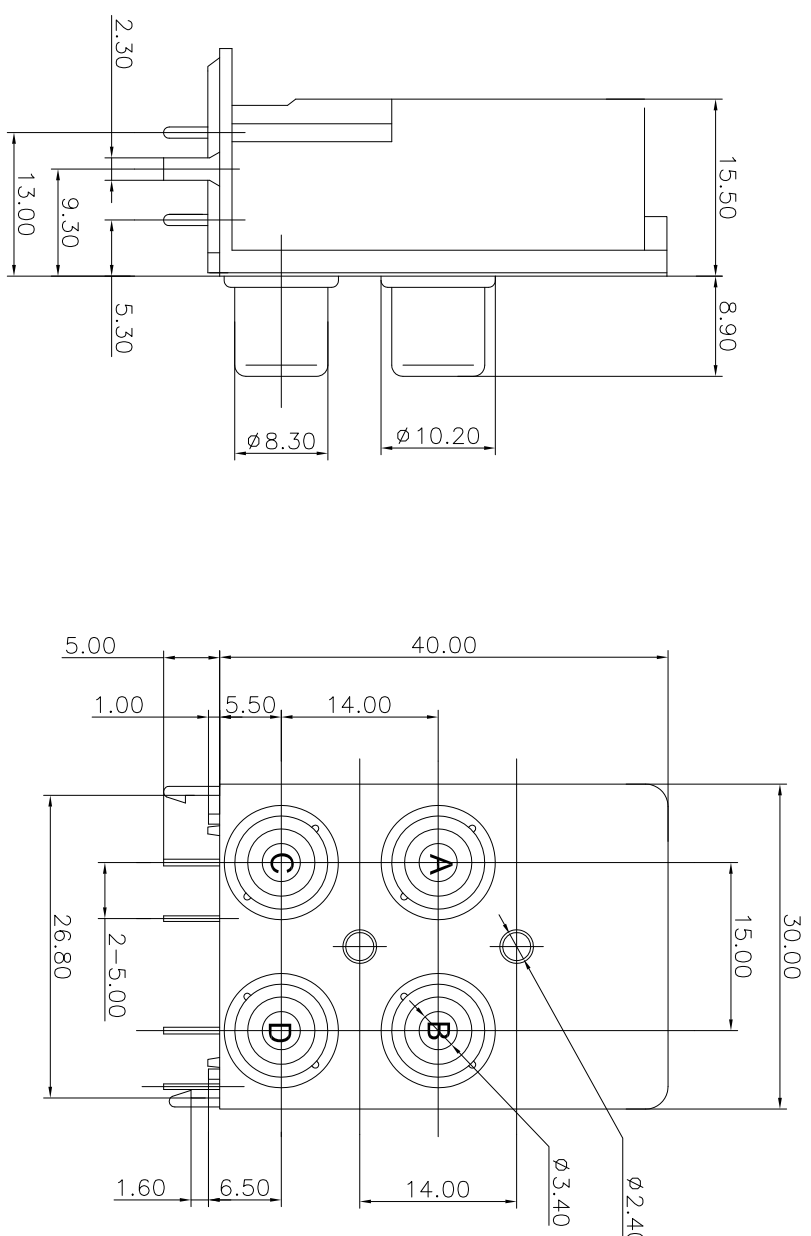

REV.	ECN NO.	MODIFIED MARK	APPROVED
A		FIRST RELEASE	

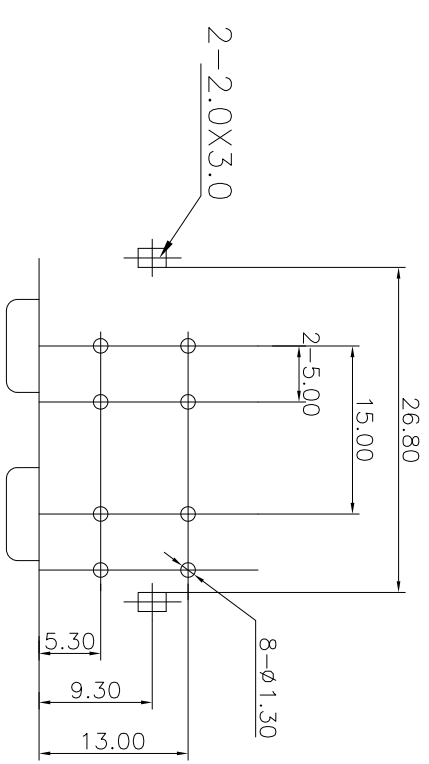

- NOTES:
- ELECTRICAL:
- 1: RATED CURRENT: 0.2A Max.
 - 2: RATED VOLTAGE: 50V AC.
 - 3: CONTACT RESISTANCE: 30 MILLIOHMS Max.
 - 4: INSULATION RESISTANCE: 100 MEGAOHMS Min.
 - 5: DIELECTRIC WITHSTANDING VOLTAGE: 500 VAC Min.
- MECHANICAL:
- 1: INSERTION FORCE: 3N-30N.
 - 2: WITHDRAWAL FORCE: 3N-30N.
 - 3: DURABILITY: 100 CYCLES.
- ENVIRONMENTAL:
- TEMPERATURE RANGE: -20°C TO 60°C.

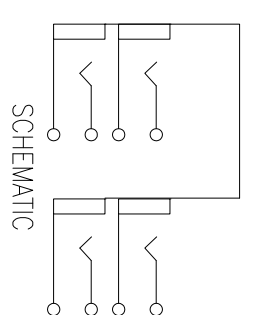
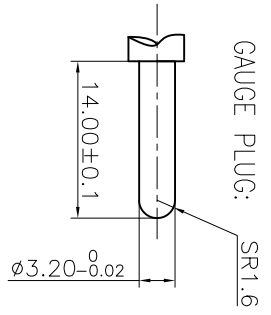

PCB LAYOUT
TOP VIEW

ANGLE	±5°	MODEL NAME: RCA-617B/P	 广东正宝科技有限公司 GUANGDONG TRENPRO TECHNOLOGY CO., LTD.
63 < L	±0.5	(PART NO.)	
16 < L ≤ 63	±0.4		
4 < L ≤ 16	±0.3		
L ≤ 4	±0.2		
TOL TABLE:		MAT'L: See table	TITLE: RCA PIN JACK
THIS DOCUMENT IS THE PROPERTY OF TRENPRO TECHNOLOGY CO., LTD. NO PART THEREOF MAY BE REPRODUCED AND USED WITHOUT THE PRIOR WRITTEN CONSENT OF THE OWNER.		FINISH: See table	DWG NO.:
		Q'TY: /	REV.: A
		APPROVED: X.Q. Hu 11/24'18	UNIT: mm
			SCALE: 5:1
			SHEET: 1/1
			SIZE: A3