

REV.	ECN NO.	MODIFIED MARK	APPROVED
A		FIRST RELEASE	

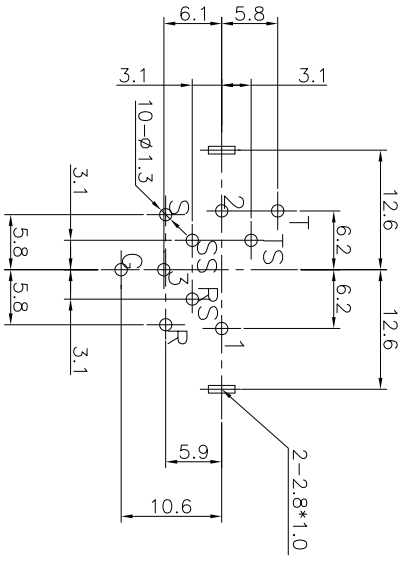

PCB LAYOUT
TOP VIEW

- NOTES:
- ELECTRICAL:
- 1: RATED CURRENT: 7.5 A MAX.
 - 2: RATED VOLTAGE: 50 V AC.
 - 3: CONTACT RESISTANCE: XLR: 30 MILLIOHMS MAX. JACK: 30 MILLIOHMS MAX.
 - 4: INSULATION RESISTANCE: 1 G OHMS MIN.
 - 5: DIELECTRIC WITHSTANDING VOLTAGE: 500 VAC MIN.
- MECHANICAL:
- 1: INSERTION FORCE: 5N~40N
 - 2: WITHDRAWAL FORCE: 5N~40N.
 - 4: DURABILITY: 1000 CYCLES.
- ENVIRONMENTAL:
- TEMPERATURE RANGE: -30°C TO 80°C.

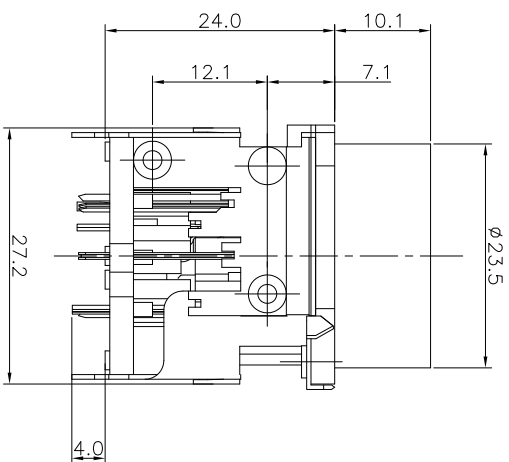
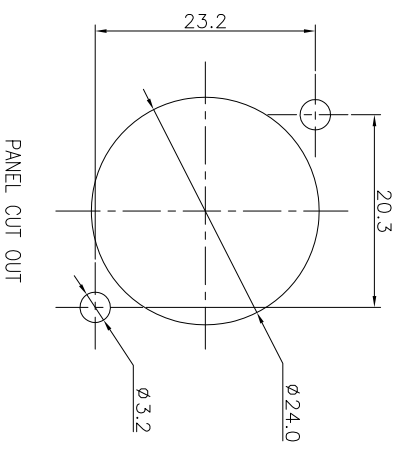
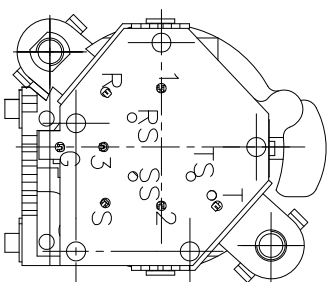
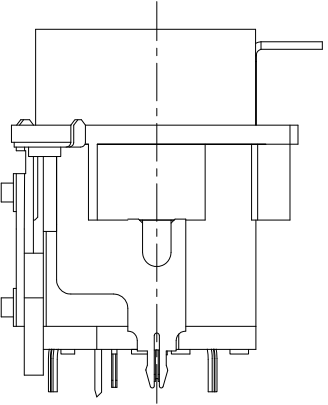
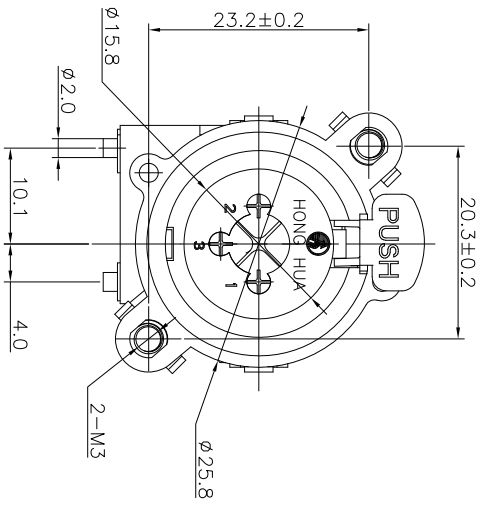
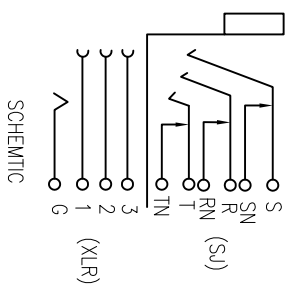

PANEL CUT OUT

ANGLE	±5°	MODEL NAME:	SPC-06A-10P	 广东正宝科技有限公司 GUANGDONG TRENPPO TECHNOLOGY CO., LTD.
63 < L	±0.5	(PART NO.)		
16 < L ≤ 63	±0.4	MAT'L:	See table	广东正宝科技有限公司 GUANGDONG TRENPPO TECHNOLOGY CO., LTD.
4 < L ≤ 16	±0.3	FINISH:	See table	
L ≤ 4	±0.2	CHECKED:	L.W.Wu 09/19'18	广东正宝科技有限公司 GUANGDONG TRENPPO TECHNOLOGY CO., LTD.
TOL TABLE:		DESIGN:	X.H.Wang 09/19'18	
THIS DOCUMENT IS THE PROPERTY OF TRENPPO TECHNOLOGY CO., LTD. NO PART THEREOF MAY BE REPRODUCED AND USED WITHOUT THE PRIOR WRITTEN CONSENT OF THE OWNER.		APPROVED:	X.Q.Hu 09/19'18	广东正宝科技有限公司 GUANGDONG TRENPPO TECHNOLOGY CO., LTD.
		UNIT:	mm	
		VIEW:	5:1	广东正宝科技有限公司 GUANGDONG TRENPPO TECHNOLOGY CO., LTD.
		SCALE:	1/1	
		SHEET:	1/1	广东正宝科技有限公司 GUANGDONG TRENPPO TECHNOLOGY CO., LTD.
		SIZE:	A3	