

REV.	ECN NO.	MODIFIED MARK	APPROVED
A		FIRST RELEASE	

- NOTES:
- ELECTRICAL:
- 1: RATED CURRENT: XLR: 20 A MAX JACK: 15 A MAX
 - 2: RATED VOLTAGE: XLR: 250 V AC JACK: 250 V AC
 - 3: CONTACT RESISTANCE: 30 MILLIOHMS MAX.
 - 4: INSULATION RESISTANCE: 1 G OHMS MIN.
 - 5: DIELECTRIC WITHSTANDING VOLTAGE: 1000 VAC MIN.
- MECHANICAL:
- 1: INSERTION FORCE: 5N~20N
 - 2: WITHDRAWAL FORCE: 5N~20N.
 - 4: DURRABILITY: 1000 CYCLES.

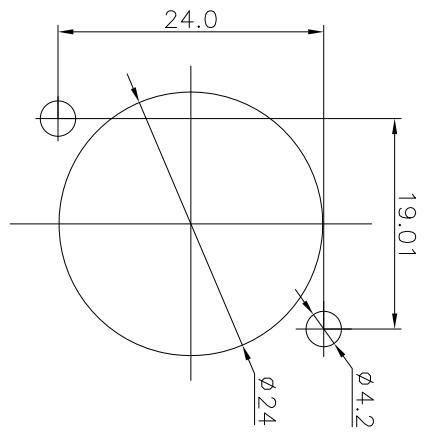

PANEL CUT OUT

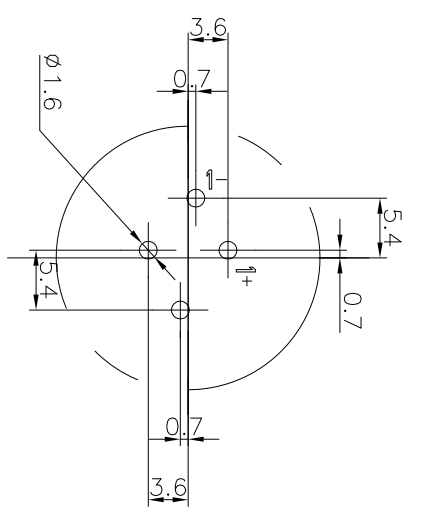

PCB LAYOUT
TOP VIEW

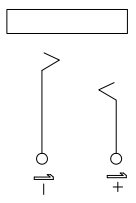
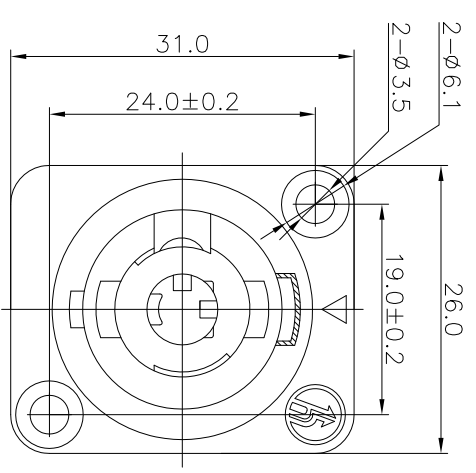
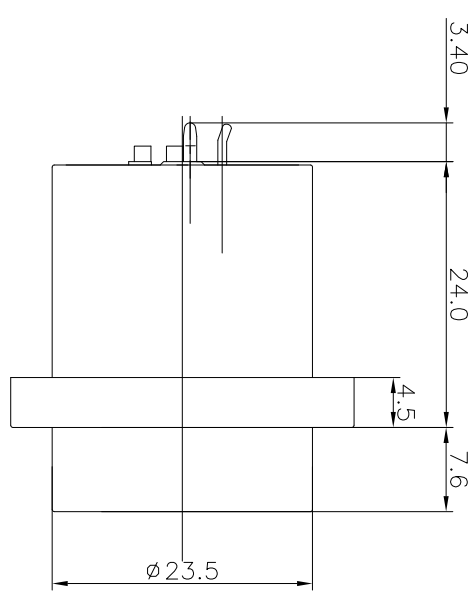
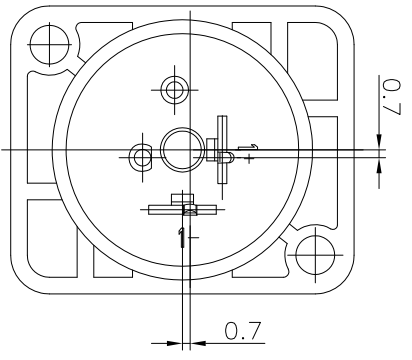

SCHEMATIC

ANGLE	±5°
63 < L	±0.5
16 < L ≤ 63	±0.4
4 < L ≤ 16	±0.3
L ≤ 4	±0.2

TOL TABLE:

THIS DOCUMENT IS THE PROPERTY OF
TRENPRO TECHNOLOGY CO.,LTD.,NO
PART THEREOF MAY BE REPRODUCED AND
USED WITHOUT THE PRIOR WRITTEN
CONSENT OF THE OWNER

MODEL NAME: SPE-20 (PART NO.)	DESIGN: Z.F.LIAN	TITLE: SPEAKON SERIES
MAT'L: See table	CHECKED: L.W.Wu	DWG NO.:
FINISH: See table	APPROVED: X.Q.Hu	DATE: 10/24/18
Q'TY: /	UNIT: mm	VIEW: 5:1

广东正宝科技有限公司
GUANGDONG TRENPRO TECHNOLOGY CO.,LTD.

