

REV.	ECN NO.	MODIFIED MARK	APPROVED
A		FIRST RELEASE	

NOTES:

ELECTRICAL:

- 1: RATED CURRENT: XLR: 20 A MAX JACK: 15 A MAX
- 2: RATED VOLTAGE: XLR: 250 V AC JACK: 250 V AC
- 3: CONTACT RESISTANCE: 30 MILLIOHMS MAX.
- 4: INSULATION RESISTANCE: 1 G OHMS MIN.
- 5: DIELECTRIC WITHSTANDING VOLTAGE: 1000 VAC MIN.

MECHANICAL:

- 1: INSERTION FORCE: 5N~20N
- 2: WITHDRAWAL FORCE: 5N~20N.
- 4: DURRABILITY: 1000 CYCLES.

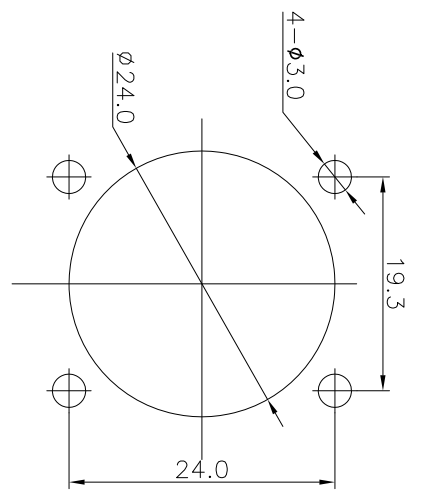

PANEL CUT OUT

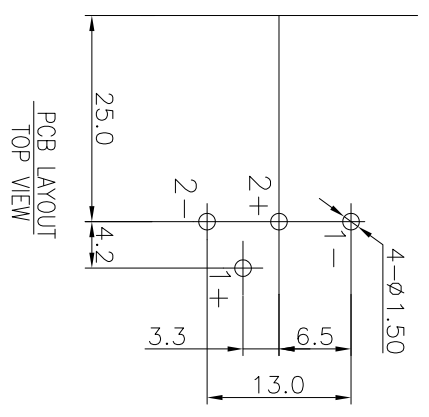

PCB LAYOUT
TOP VIEW

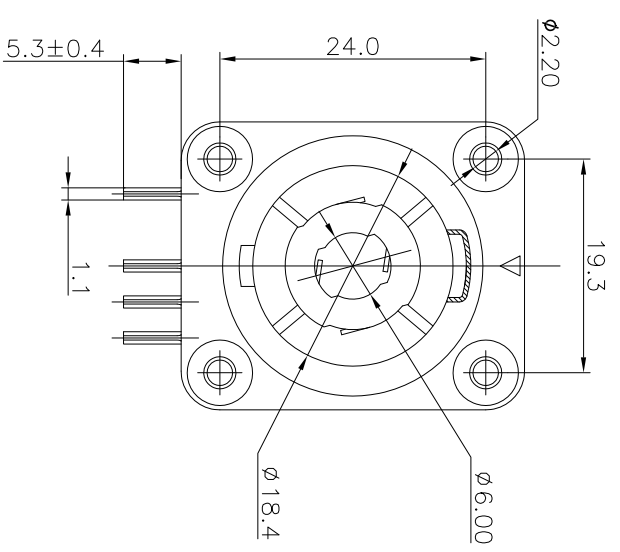
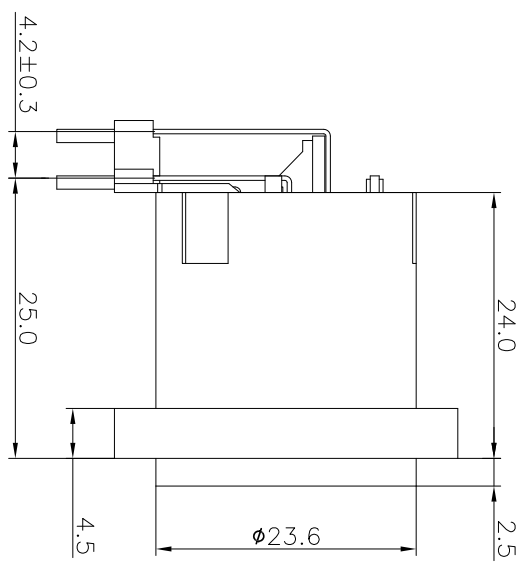
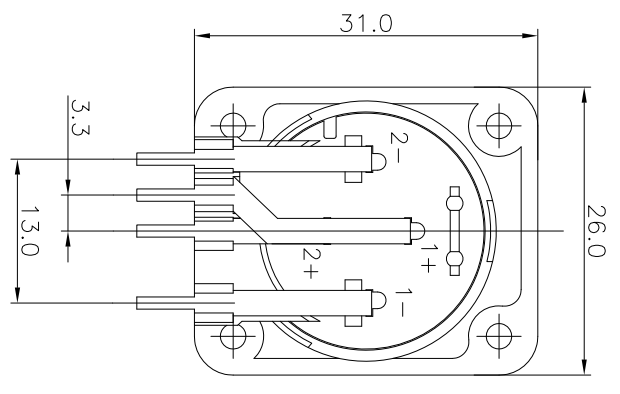

ANGLE	±5°
63 < L	±0.5
16 < L ≤ 63	±0.4
4 < L ≤ 16	±0.3
L ≤ 4	±0.2

TOL TABLE:

THIS DOCUMENT IS THE PROPERTY OF
TRENPRO TECHNOLOGY CO.,LTD.,NO
PART THEREOF MAY BE REPRODUCED AND
USED WITHOUT THE PRIOR WRITTEN
CONSENT OF THE OWNER

MODEL NAME: SPE-07 (PART NO.)	DESIGN: Z.F.LIAN	TITLE: SPEAKON SERIES	REV.: A
MAT'L: See table	CHECKED: L.W.Wu	DWG NO.:	
FINISH: See table	10/24'18		
Q'TY: /	APPROVED: X.Q.Hu	UNIT: mm	SCALE: 5:1
	10/24'18	VIEW: 1/1	SHEET: 1/1
			SIZE: A3

