

REV. A	ECN NO.	MODIFIED MARK	APPROVED
		FIRST RELEASE	

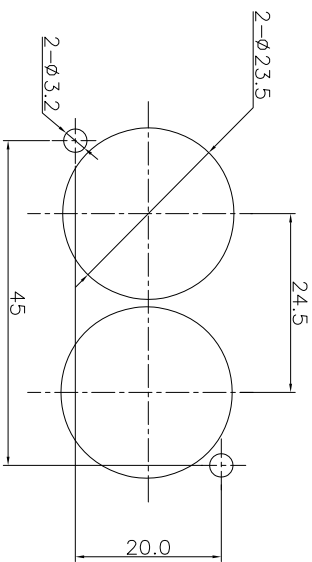

NOTES:

ELECTRICAL:

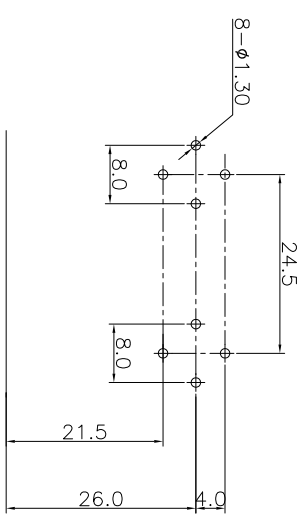
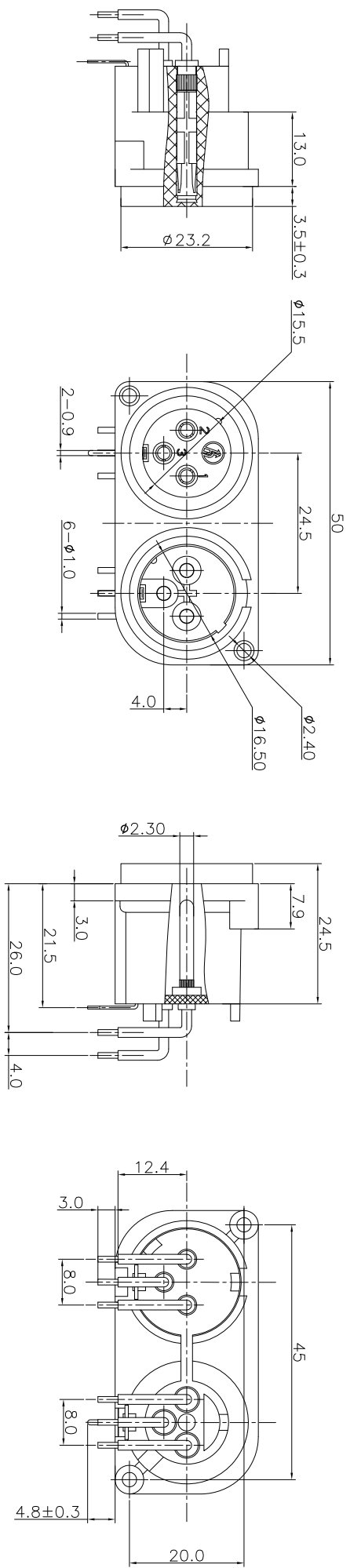

- 1:RATED CURRENT: 6A Max.
- 2:RATED VOLTAGE: 50V AC.
- 3:CONTACT RESISTANCE: 30 MILLIOHMS Max.
- 4:INSULATION RESISTANCE: 1G OHMS Min.
- 5:DILECTRIC WITHSTANDING VOLTAGE: 500 VAC Min.

MECHANICAL:

- 1:INSERTION FORCE: 5N-40N.
- 2:WITHDRAWAL FORCE: 5N-40N.
- 3:DURABILITY: 1000 CYCLES.

ENVIRONMENTAL:

TEMPERATURE RANGE: -30°C TO 80°C.

ANGLE	$\pm 5^\circ$	MODEL NAME: SPC-10	 广东正宝科技有限公司 GUANGDONG TRENPPO TECHNOLOGY CO., LTD.	TITLE: XLR CABLE CONNECTORS	REV.: A
63 < L	$\pm 0.5$	(PART NO.)		DESIGN: X.H.Wang 09/19'18	DWG NO.:
16 < L ≤ 63	$\pm 0.4$		CHECKED: L.W.Wu 09/19'18	UNIT: mm	VIEW: 
4 < L ≤ 16	$\pm 0.3$		FINISH: See table	SCALE: 5:1	SHEET: 1/1
L ≤ 4	$\pm 0.2$		MAT'L: See table	APPROVED: X.Q.Hu 09/19'18	SIZE: A3

TOL TABLE:

THIS DOCUMENT IS THE PROPERTY OF  
TRENPRO TECHNOLOGY CO., LTD.  
NO PART THEREOF MAY BE REPRODUCED  
AND USED WITHOUT THE PRIOR WRITTEN  
CONSENT OF THE OWNER