

| | | | |
|------|---------|---------------|----------|
| REV. | ECN NO. | MODIFIED MARK | APPROVED |
| A | | FIRST RELEASE | |

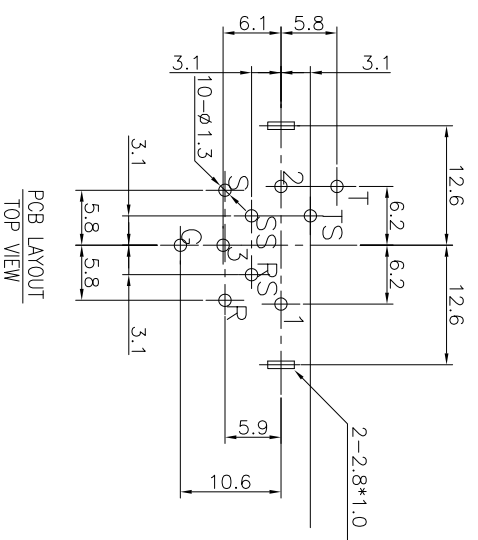

- NOTES:
- ELECTRICAL:
- 1: RATED CURRENT: 7.5 A MAX.
 - 2: RATED VOLTAGE: 50 V AC.
 - 3: CONTACT RESISTANCE: XLR: 30 MILLIOHMS MAX. JACK: 30 MILLIOHMS MAX.
 - 4: INSULATION RESISTANCE: 1 G OHMS MIN.
 - 5: DIELECTRIC WITHSTANDING VOLTAGE: 500 VAC MIN.
- MECHANICAL:
- 1: INSERTION FORCE: 5N~40N
 - 2: WITHDRAWAL FORCE: 5N~40N.
 - 4: DURABILITY: 1000 CYCLES.
- ENVIRONMENTAL:
- TEMPERATURE RANGE: -30°C TO 80°C.

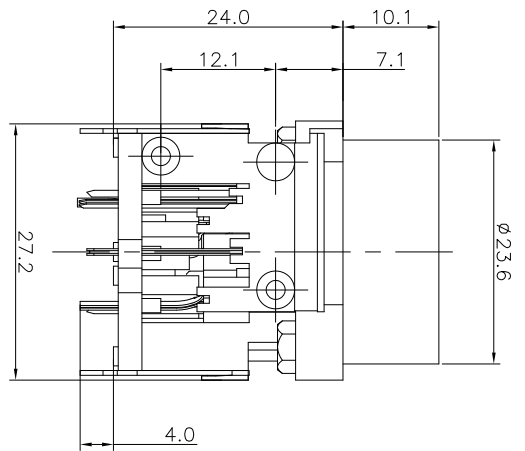
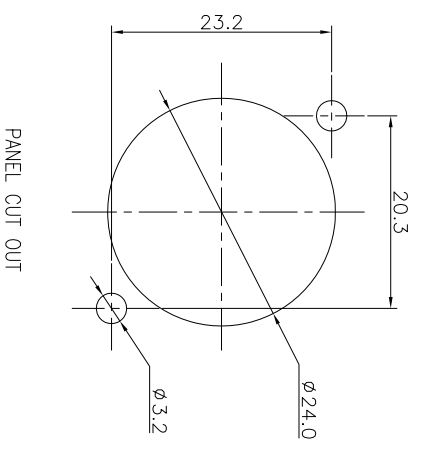
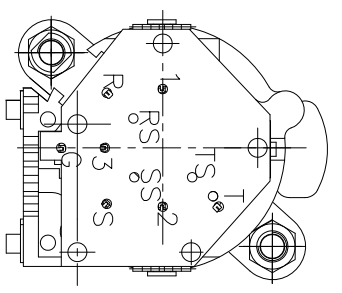
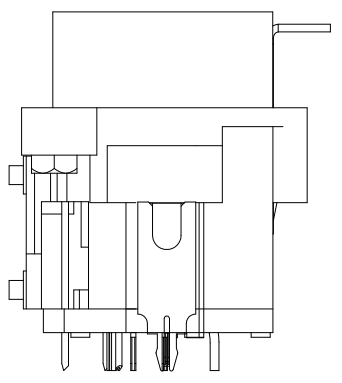
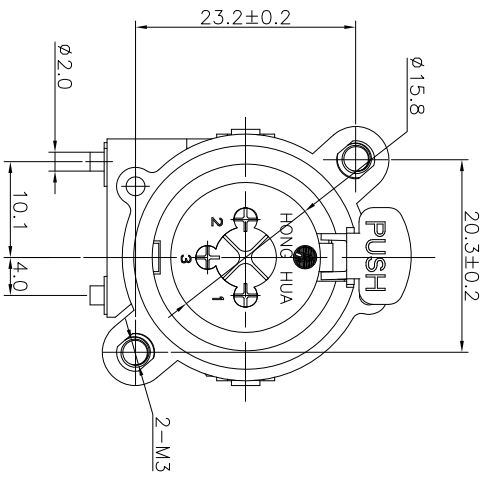
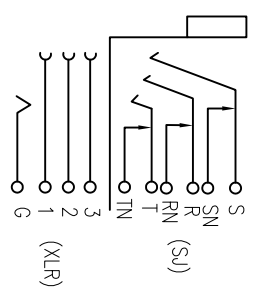

| | | | | | | | | |
|---|------|-------------|-------------------|--|----------------------|--------|--------|-------|
| ANGLE | ±5° | MODEL NAME: | SPC-05A-10P | 广东正宝科技有限公司 GUANGDONG TRENPPO TECHNOLOGY CO., LTD. | | | | |
| 63 < L | ±0.5 | (PART NO.) | | | | | | |
| 16 < L ≤ 63 | ±0.4 | DESIGN: | X.H.Wang 09/19'18 | TITLE: | XLR CABLE CONNECTORS | | | |
| 4 < L ≤ 16 | ±0.3 | CHECKED: | L.W.Wu 09/19'18 | DWG NO.: | | | | |
| L ≤ 4 | ±0.2 | FINISH: | See table | UNIT: | mm | | | |
| TOL TABLE: | | Q'TY: / | APPROVED: | X.Q.Hu 09/19'18 | VIEW: | SCALE: | SHEET: | SIZE: |
| THIS DOCUMENT IS THE PROPERTY OF TRENPPO TECHNOLOGY CO., LTD. NO PART THEREOF MAY BE REPRODUCED AND USED WITHOUT THE PRIOR WRITTEN CONSENT OF THE OWNER | | | | | | 5:1 | 1/1 | A3 |