

REV.	ECN NO.	MODIFIED MARK	APPROVED
A		FIRST RELEASE	

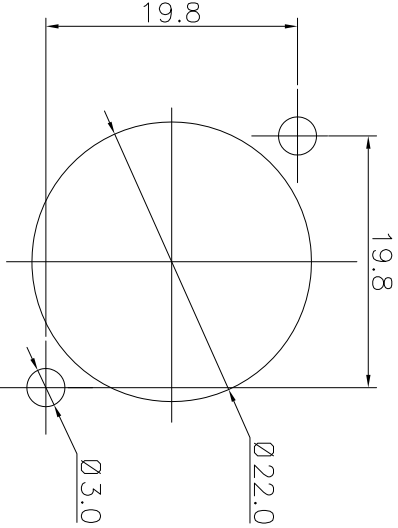

PANEL CUTOUT

- NOTES:
- ELECTRICAL:
- 1: RATED CURRENT: 6A Max.
 - 2: RATED VOLTAGE: 50V AC.
 - 3: CONTACT RESISTANCE: 30 MILLIOHMS Max.
 - 4: INSULATION RESISTANCE: 1G OHMS Min.
 - 5: DIELECTRIC WITHSTANDING VOLTAGE: 500 VAC Min.
- MECHANICAL:
- 1: INSERTION FORCE: 5N-40N.
 - 2: WITHDRAWAL FORCE: 5N-40N.
 - 3: DURABILITY: 1000 CYCLES.
- ENVIRONMENTAL:
- TEMPERATURE RANGE: -30°C TO 80°C.

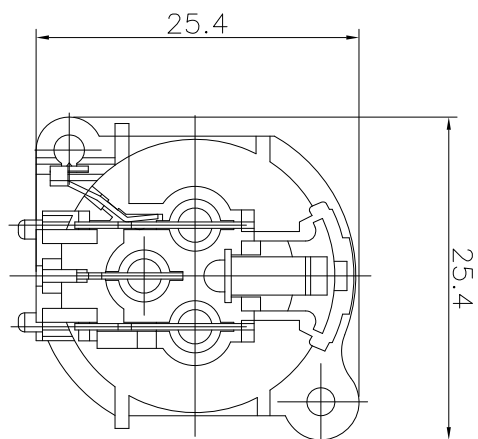
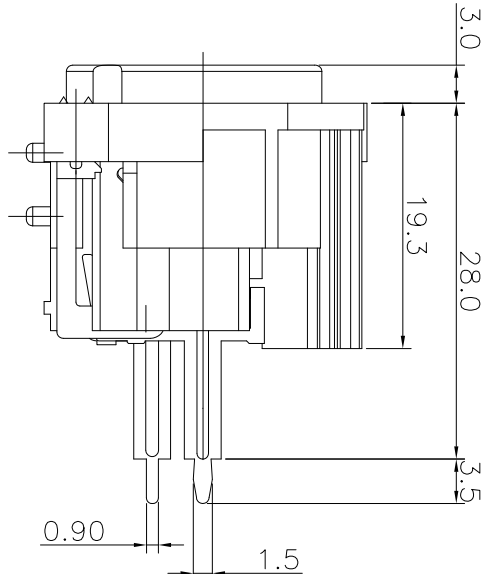
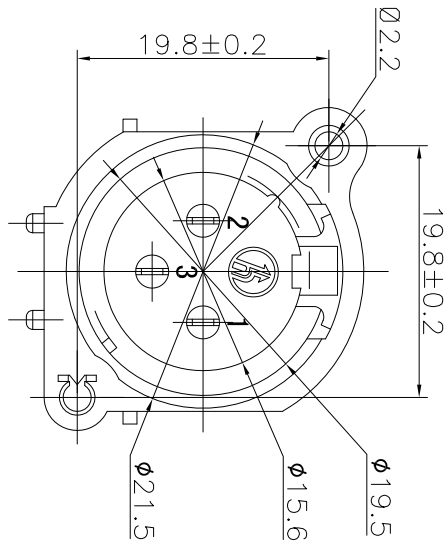
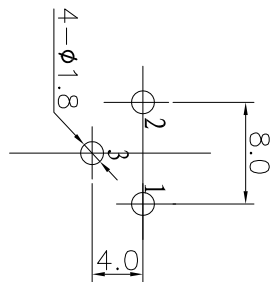

PCB LAYOUT
TOP VIEW

ANGLE	±5°
63 < L	±0.5
16 < L ≤ 63	±0.4
4 < L ≤ 16	±0.3
L ≤ 4	±0.2

TOL TABLE:

THIS DOCUMENT IS THE PROPERTY OF
TERPRO TECHNOLOGY CO., LTD. NO PART
HEREOF MAY BE REPRODUCED AND
USED WITHOUT THE PRIOR WRITTEN
CONSENT OF THE OWNER

MODEL NAME: SPF-25BL (PART NO.)	DESIGN: X.H.Wong 08/31'18	TITLE: XLR CABLE CONNECTORS	REV.: A
MAT'L: See table	CHECKED: L.W.Wu 08/31'18	DWG NO.:	
FINISH: See table	APPROVED: X.Q.Hu 08/31'18	UNIT: mm	SCALE: 5:1
Q'TY: /		VIEW:	SHEET: 1/1
			SIZE: A3

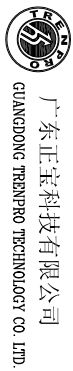

广东正宝科技有限公司
GUANGDONG TERPRO TECHNOLOGY CO., LTD.