

REV.	ECN NO.	MODIFIED MARK	APPROVED
A		FIRST RELEASE	

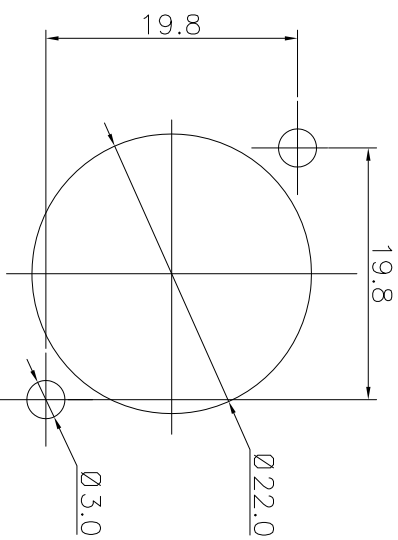

PANEL CUTOUT

- NOTES:
- ELECTRICAL:
- 1: RATED CURRENT: 6A Max.
  - 2: RATED VOLTAGE: 50V AC.
  - 3: CONTACT RESISTANCE: 30 MILLIOHMS Max.
  - 4: INSULATION RESISTANCE: 1G OHMS Min.
  - 5: DIELECTRIC WITHSTANDING VOLTAGE: 500 VAC Min.
- MECHANICAL:
- 1: INSERTION FORCE: 5N-40N.
  - 2: WITHDRAWAL FORCE: 5N-40N.
  - 3: DURABILITY: 1000 CYCLES.
- ENVIRONMENTAL:
- TEMPERATURE RANGE: -30°C TO 80°C.

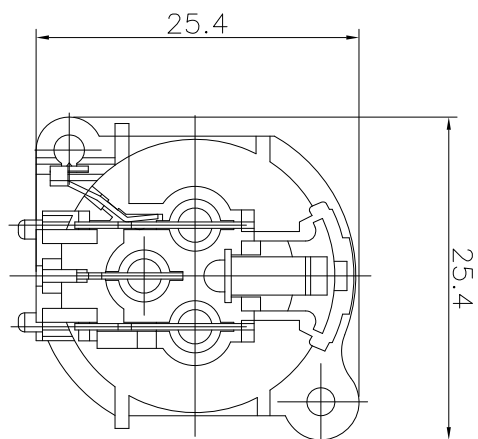
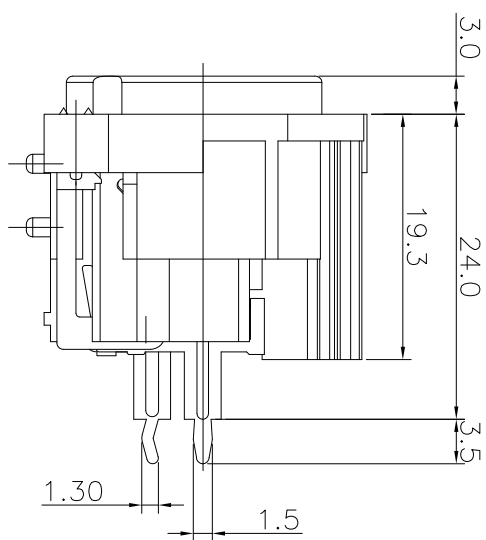
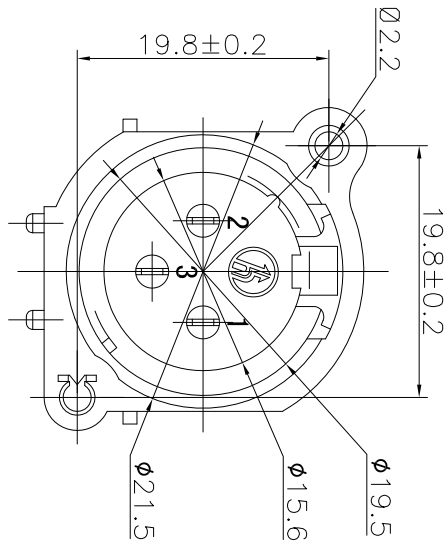
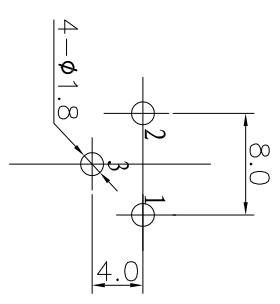

PCB LAYOUT  
TOP VIEW

ANGLE	±5°	MODEL NAME: SPF-25 (PART NO.)	 广东正宝科技有限公司 GUANGDONG TRENPRO TECHNOLOGY CO., LTD.	TITLE: XLR CABLE CONNECTORS	REV.: A
63 < L	±0.5	MAT'L: See table		DWG NO.:	UNIT: mm
16 < L ≤ 63	±0.4	FINISH: See table	CHECKED: L.W.Wu 08/31'18	APPROVED: X.Q.Hu 08/31'18	SHEET: 1/1
4 < L ≤ 16	±0.3	Q'TY: /			SIZE: A3
L ≤ 4	±0.2				

TOL TABLE:

THIS DOCUMENT IS THE PROPERTY OF  
TRENPRO TECHNOLOGY CO., LTD. NO PART  
THEREOF MAY BE REPRODUCED AND  
USED WITHOUT THE PRIOR WRITTEN  
CONSENT OF THE OWNER