

REV.	ECN NO.	MODIFIED MARK	APPROVED
A		FIRST RELEASE	

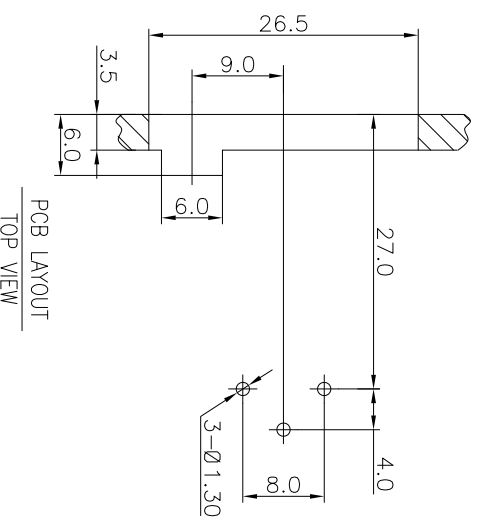
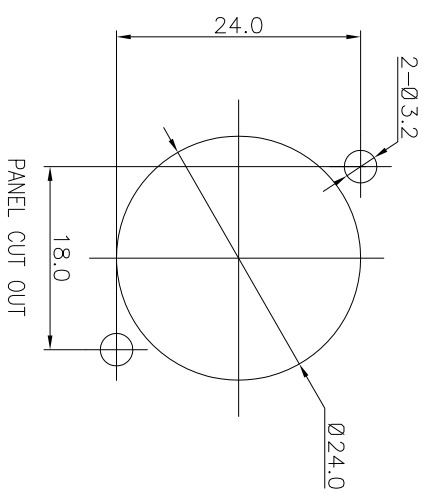
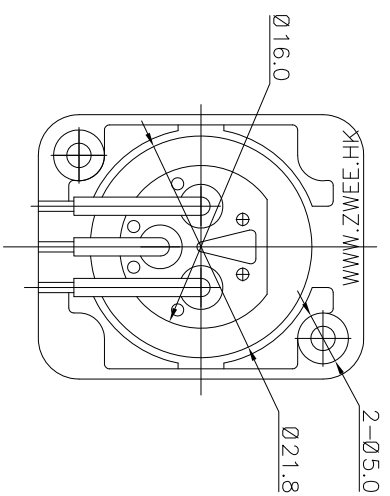
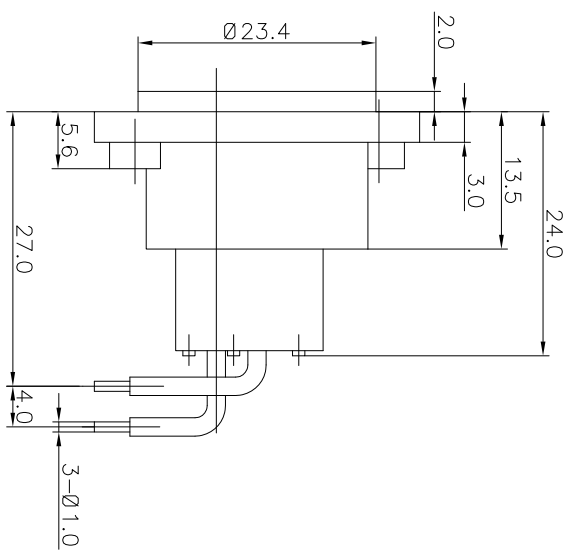
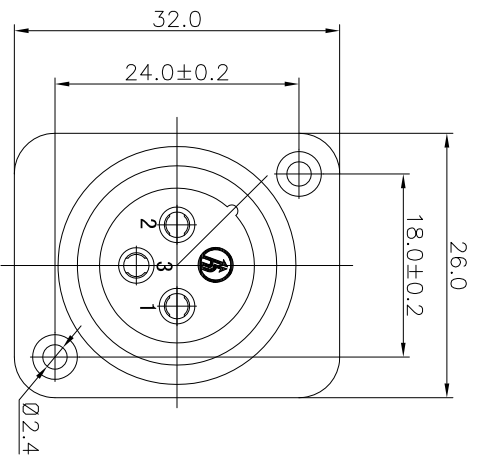

NOTES:  
ELECTRICAL:  
1:RATED CURRENT: 6A Max.  
2:RATED VOLTAGE: 50V AC.  
3:CONTACT RESISTANCE: 30 MILLIOHMS Max.  
AFTER TESTING:60 MILLIOHMS Max.  
4:INSULATION RESISTANCE: 1G OHMS Min.  
5:DIIELECTRIC WITHSTANDING VOLTAGE: 500 VAC Min.  
MECHANICAL:  
1:INSERTION FORCE: 5N-40N.  
2:WITHDRAWAL FORCE: 5N-40N.  
3:DURRABILITY: 1000 CYCLES.  
ENVIRONMENTAL:  
TEMPERATURE RANGE: -30°C TO 80°C.

ANGLE	±5°
63 < L	±0.5
16 < L ≤ 63	±0.4
4 < L ≤ 16	±0.3
L ≤ 4	±0.2

TOL TABLE:  
THIS DOCUMENT IS THE PROPERTY OF  
TERPRO TECHNOLOGY CO., LTD.,NO PART  
THEREOF MAY BE REPRODUCED AND  
USED WITHOUT THE PRIOR WRITTEN  
CONSENT OF THE OWNER

MODEL NAME: SPF-19M (PART NO.)	DESIGN: X.H.Wong 08/31'18	TITLE: XLR CABLE CONNECTORS	REV.: A
MAT'L: See table	CHECKED: L.W.Wu 08/31'18	DWG NO.:	
FINISH: See table	APPROVED: X.Q.Hu 08/31'18	UNIT: mm	VIEW: 5:1
Q'TY: /		SCALE: SHEET: 1/1	SIZE: A3

