

REV.	ECN NO.	MODIFIED MARK	APPROVED
A		FIRST RELEASE	

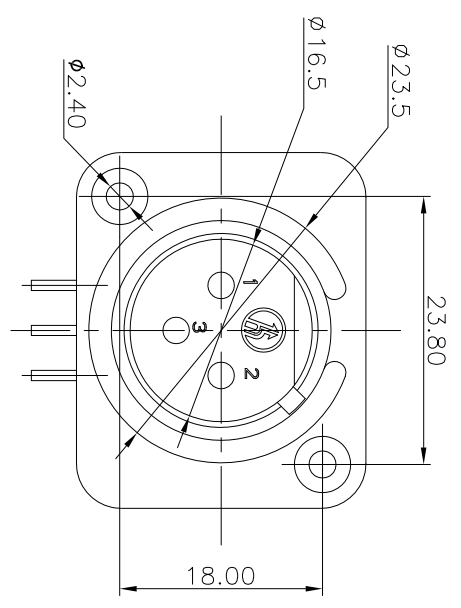

- NOTES:
- ELECTRICAL:
- 1:RATED CURRENT: 6A Max.
  - 2:RATED VOLTAGE: 50V AC.
  - 3:CONTACT RESISTANCE: 30 MILLIOHMS Max.
  - 4:INSULATION RESISTANCE: 1G OHMS Min.
  - 5:DIELECTRIC WITHSTANDING VOLTAGE: 500 VAC Min.
- MECHANICAL:
- 1:INSERTION FORCE: 5N-40N.
  - 2:WITHDRAWAL FORCE: 5N-40N.
  - 3:DURABILITY: 1000 CYCLES.
- ENVIRONMENTAL:
- TEMPERATURE RANGE: -30°C TO 80°C.

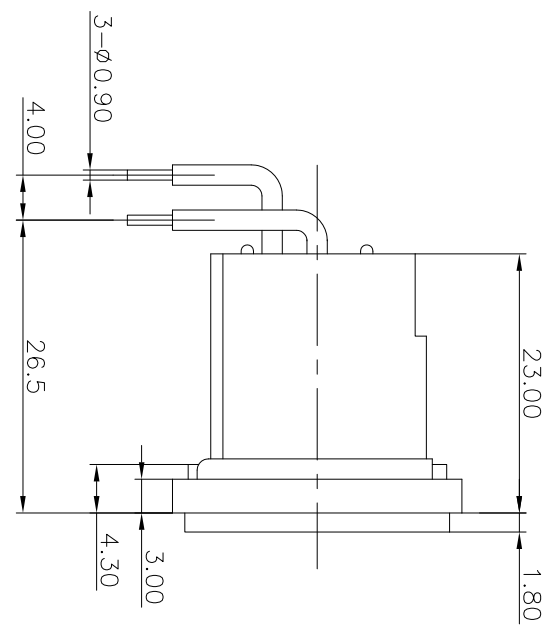
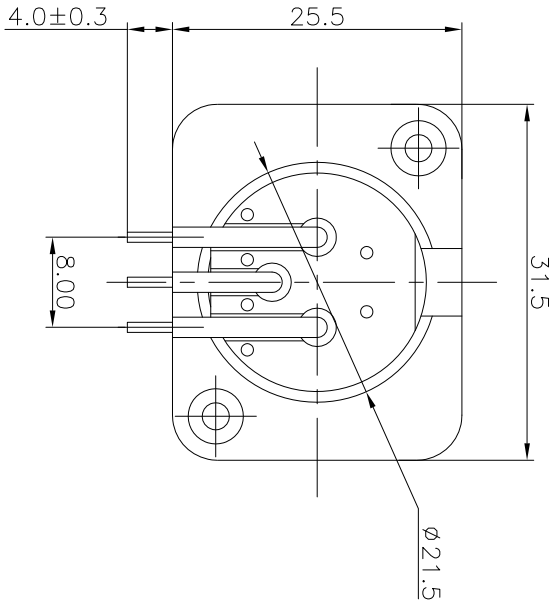
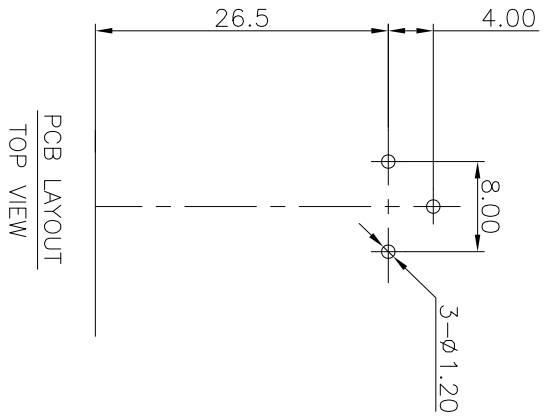

PCB LAYOUT  
TOP VIEW

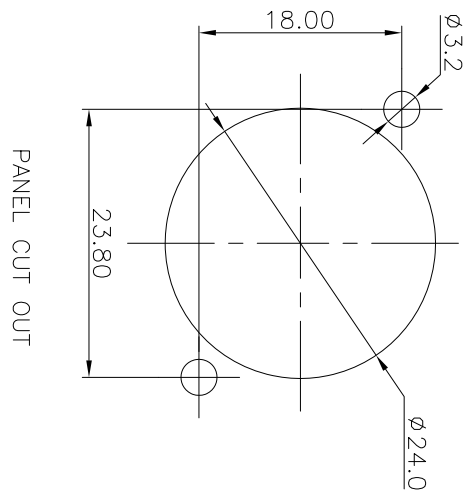

PANEL CUT OUT

ANGLE	±5°	MODEL NAME: SPM-19	 广东正宝科技有限公司 GUANGDONG TRENPRO TECHNOLOGY CO., LTD.
63 < L	±0.5	(PART NO.)	
16 < L ≤ 63	±0.4	MAT'L:	DESIGN: X.H.Wong 09/08'18
4 < L ≤ 16	±0.3	FINISH:	CHECKED: L.W.Wu 09/08'18
L ≤ 4	±0.2	See table	TITLE: XLR CABLE CONNECTORS
TOL TABLE:		Q'TY./	APPROVED: X.Q.Hu 09/08'18
THIS DOCUMENT IS THE PROPERTY OF TRENPRO TECHNOLOGY CO., LTD. NO PART THEREOF MAY BE REPRODUCED AND USED WITHOUT THE PRIOR WRITTEN CONSENT OF THE OWNER		UNIT: mm	VIEW: 5:1
		SCALE: SHEET: 1/1	REV.: A
		SIZE: A3	